

Constant voltage charging characteristics

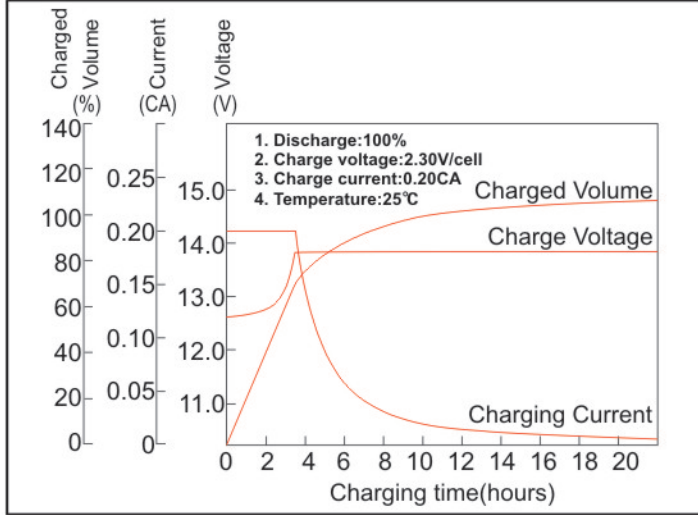

Float Life

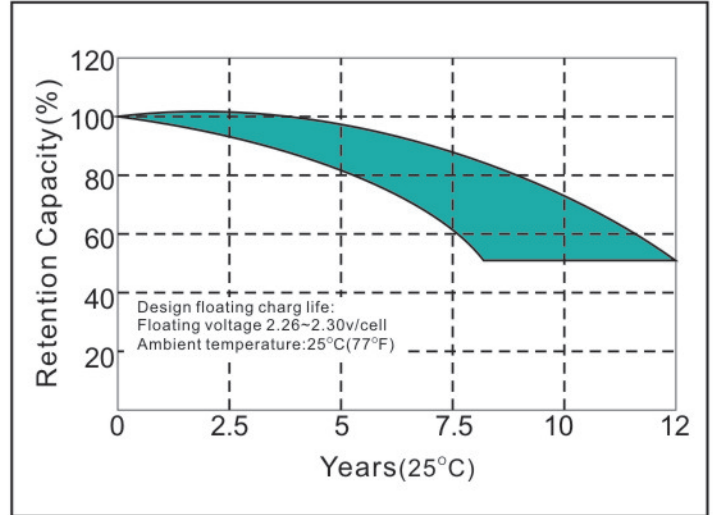

Constant Current Discharge Characteristics(A,25°C)

F.V/Time	15min	30min	60min	2h	3h	4h	5h	8h	10h	20h
9.60V	333.0	189.0	117.0	65.8	49.5	37.6	34.4	21.9	18.2	9.4
10.2V	319.5	181.8	112.5	64.8	48.2	37.2	33.3	21.7	18.1	9.3
10.5V	313.2	177.3	109.8	64.3	47.8	36.9	33.0	21.5	18.1	9.2
10.8V	303.3	172.8	107.1	63.5	46.7	35.8	32.7	21.3	18.0	9.2

Constant Power Discharge Characteristic(Watt,25°C)

F.V/Time	15min	30min	60min	2h	3h	4h	5h	8h	10h	20h
9.60V	3656.7	2120.4	1333.8	761.4	575.1	442.8	399.6	259.2	217.8	111.6
10.2V	3510.0	2035.8	1282.5	749.7	566.1	437.4	393.3	257.4	216.7	110.7
10.5V	3438.9	1989.0	1251.0	743.4	561.6	433.8	389.7	256.5	216.0	109.8
10.8V	3334.5	1934.1	1216.8	734.4	555.3	421.2	386.1	252.9	215.2	109.2

Capacity Factors With Different Temperature

Battery Type		-20°C	-10°C	0°C	5°C	10°C	20°C	25°C	30°C	40°C	45°C
Battery	12V	50%	70%	83%	85%	90%	98%	100%	102%	104%	105%

★The above are average and data obtained from the first 3 charge/discharge cycles. These are not minimum values.

MODEL: PR180-12

NO.: 302010005-00198

POWER
AGM

Cycle service life in relation to the depth of discharge

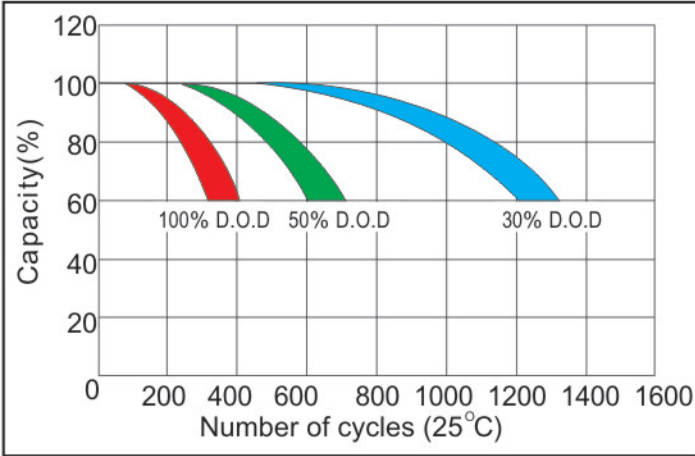

Plane Chart:

Unit:(mm) Terminal type:(B6)

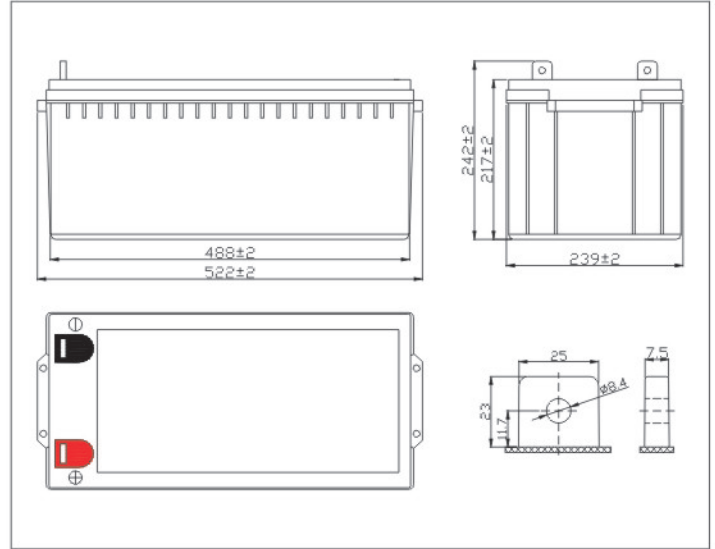

ISO 9001
ISO 14001
OHSAS18001



Parameter Chart:

Volts		12V	
Capacity(25°C)	10 hours rate (18A)	180Ah	
Discharge Current Testing (25°C)	1 hours rate (99A)	100Ah	
	3 hours rate (45A)	137Ah	
Internal Resistance	Full Charged Battery 25°C	3.7mΩ	
Capacity Affected By Temperature	40°C	104%	
	25°C	100%	
	0°C	83%	
	-15°C	65%	
Residual Capacity (25°C)	Capacity After 3 Months Storage	91%	
	Capacity After 6 Months Storage	82%	
	Capacity After 12 Months Storage	65%	
Charge (Constant Voltage)	Cycle (25°C)	Initial Charging Current Less Than 54A Voltage 14.5~14.9V	
	Float (25°C)	Charge Voltage 13.6~13.8V	
Weight (Approx)		54.0Kg	

Residual Capacity

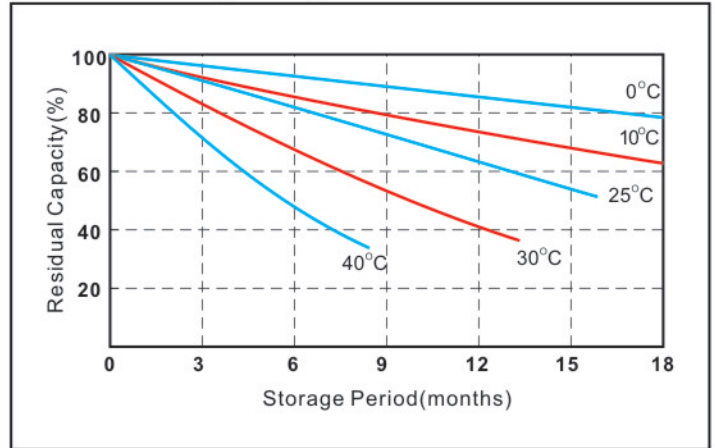

Discharge Current 25°C

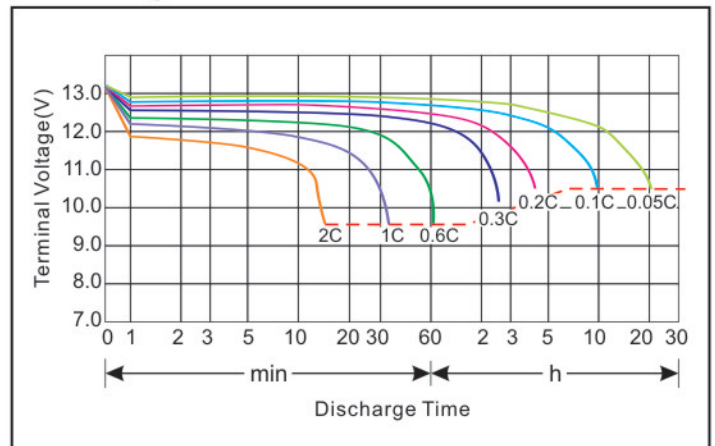

★The above are average and data obtained from the first 3 charge/discharge cycles. These are not minimum values.